

WATERAX



MSTR-C MINI-STRIKER® cart kit

DATA SHEET

MINI-STRIKER® 2.5 HP PORTABLE CART SYSTEM

The WATERAX MINI-STRIKER® Fire Pump Cart System, fully equipped with professional grade equipment such as HOTLINE® forestry hose, a suction hose, a Scotty nozzle, a camloc fitting, an instantaneous fitting, a foot valve & strainer and a universal Hose Wrench and a reliable single stage pump end with the Honda 4-stroke 2.5 HP engine to achieve pressures of up to 85 PSI (5.9 BAR) and offer volume supply of up to 80 GPM (303 L/Min). The convenient package will allow the user to quickly respond to fires on their property and defensible space.

Emissions compliant; engine is CARB and EPA certified

Applications

- Attack line firefighting
- Sprinkler operations
- Irrigation

Features and Benefits

- Lightweight aluminum alloy pump components
- Flat free 10 inch wheels
- Easy transport and compact
- Turnkey solution
- EPA certified.



**WE MOVE
WATER**

SPECIFICATIONS

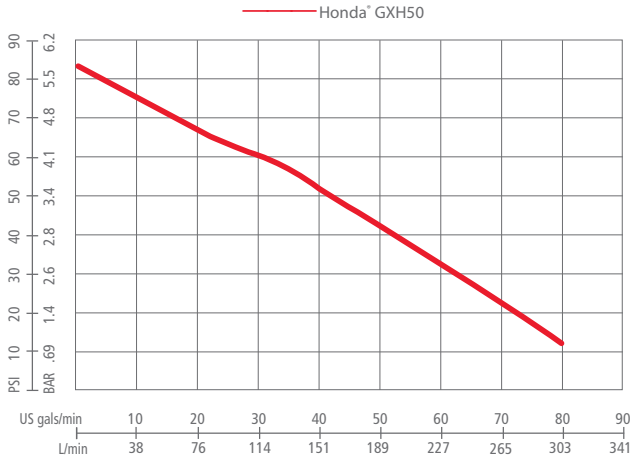

Engine brand: Honda GXH50 Series

Engine type: Gas 4-Stroke

Flow rate at specified pressure

Maximum Pressure : 85 PSI (5.9 bar)

Free flow : 80 US gals/min (303 L/min)

Maximum Head: 196' (60m)

Flow Rate			Pressure	
US GPM	(LPM)	@	PSI	(BAR)
68	(257)	@	25	(1.7)
42	(159)	@	50	(3.4)
12	(45)	@	75	(5.2)

Engine Specifications

Model & Type	Honda, GXH50 Series 4-stroke, horizontal shaft, single cylinder, OHV
Net Power Output	2.1 HP (1.6 kW) @ 7000 RPM
Net Torque	2.0 lb-ft (2.7 Nm) @ 4500 RPM
Bore & Stroke	1.65 x 1.42 inches (41.8 x 36 mm)
Displacement	3.01 cubic inches (49.4 cc)
Starting System	Recoil
Ignition	Transistorized Magneto
Governor	Centrifugal Mechanical
Air Cleaner	Semi-dry
Cooling	Air Cooled
Lubrication	Forced Splash
Oil Capacity	0.26 quarts (0.25 liters)
Carburetor	Float Type
Emissions	Meets current CARB, EPA, and CE requirements
Exhaust	US Forestry Service Approved Spark Arrestor
Fuel Type	Gasoline [unleaded, 86 minimum octane or higher, 10% maximum ethanol]
Fuel Tank:	Integral 0.81 quarts (0.77 liters)
Fuel Consumption	0.24 US gal/hr (0.91 L/hr)

Pump Specifications

Type	Single Stage Centrifugal; Direct Drive
Description	Foam Compatible
Maximum Allowable Pressure	200 PSI (13.8 bar)
Maximum Pressure	85 PSI (5.9 bar)
Maximum Flow	80 GPM (303 lpm)
Intake	1-1/2" Male NPSH Thread.
Discharge	1-1/2" Male NPSH Thread.
Body & Diffusers	Anodized corrosive resistant aluminum
Impellers	Anodized corrosive resistant aluminum
Pump Shaft	Stainless Steel
Pump Seal	Heat Resistant Rotary Mechanical Seal – Maintenance Free
Color	Red

Controls

Engine choke, shut-off, throttle, and fuel valve control levers with low oil pressure shutdown.

Frame Specifications:

Cart Kit: Cart system with 10" wheels and equipment pouch.

Kit Details:

Equipment included: HOTLINE forestry hose, a suction hose, a Scotty nozzle, a camloc fitting, an instantaneous fitting, a footvalve and strainer and a universal hose wrench.



TECHNICAL DRAWINGS

MSTR-C

Length 19-3/4" (50 cm) Width 26-1/2" (67 cm) Height 45-1/4" (115 cm) Weight 65 lbs (29.5 kg)

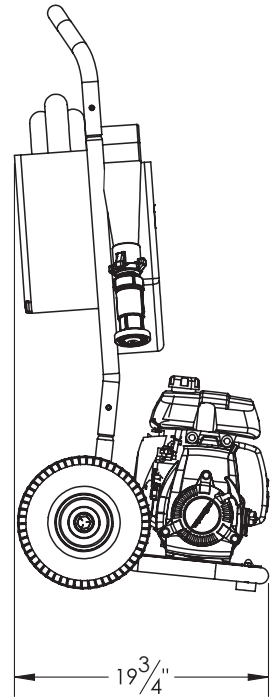
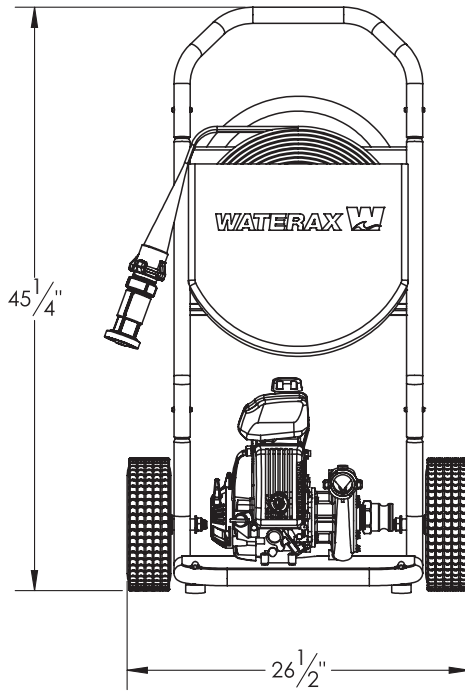
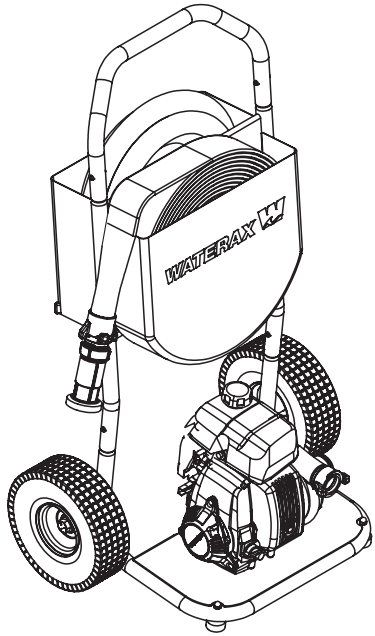

**WE MOVE
WATER**

WATERAX

All information contained in this document including drawings is proprietary to *WATERAX* and may not be copied, reproduced or used in whole or in part without our prior written permission. The information in this document is subject to change without notice. Model displayed with multiple options. Weight and dimensions are approximated and may vary depending on options.

WATERAX INC.

6635 Henri-Bourassa W.
Montreal, QC H4R 1E1
T 514 637-1818
F 514 637-3985
TF 1 855 616 616-1818
info@waterax.com

waterax.com

To help you stay **#ReadyForWildfires**, we've made a few changes, placing 100% of our focus on manufacturing our core products, portable fire pumps.

To do so, we've established a network of trusted supply and distribution partners that can help us provide *WATERAX* pumps quickly in addition to water-handling equipment and accessories.

For immediate assistance when it comes to pumps and water-handling accessories, please contact your local dealer.

For genuine spare parts, visit our online store.

MINI-STRIKER® is a trademark of Waterax.



**WE MOVE
WATER**